

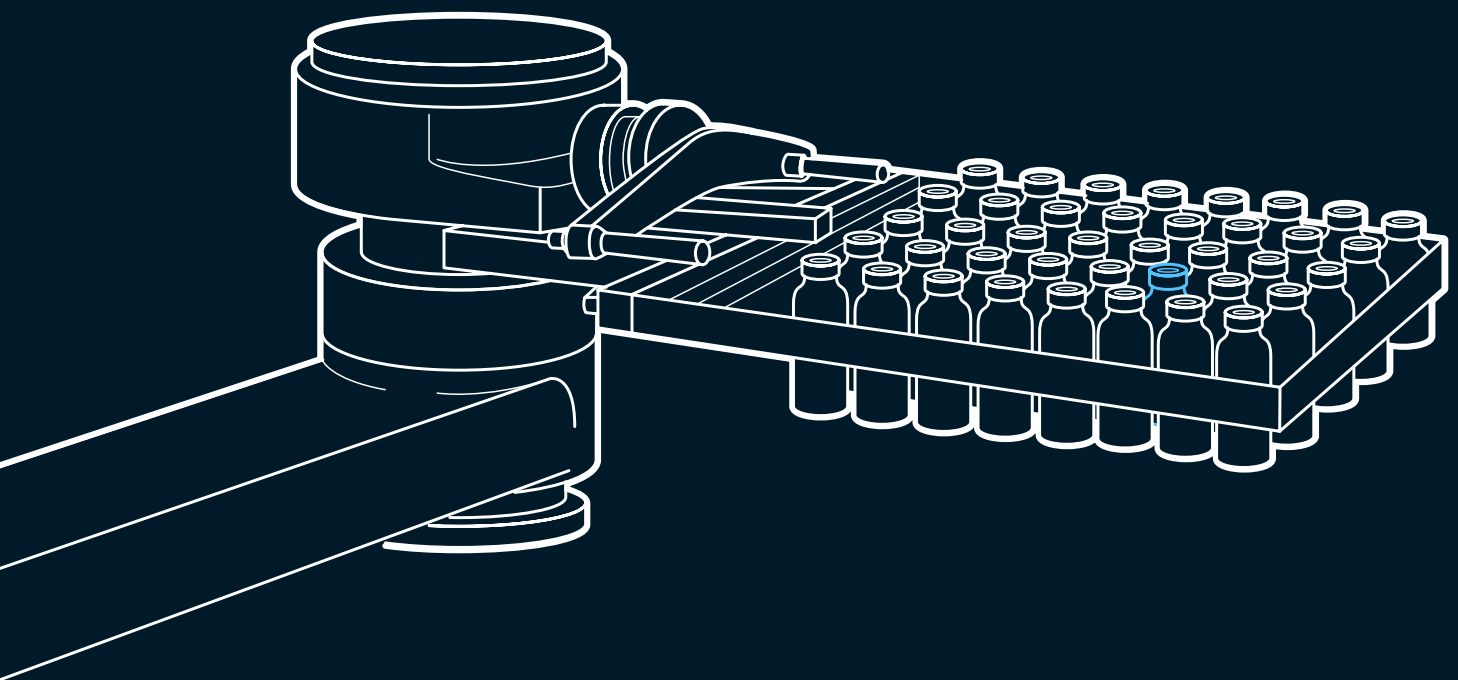

**Drug Product  
Contract Manufacturing Services**

Robotic Gloveless  
GMP Fill & Finish for Sterile Injectables



# Introduction to Our Company

White Raven has been established in 2023 with the mission to expedite the journey of emerging biopharma companies for getting their products on the market. By offering an unmatched flexibility, White Raven, a Fill & Finish CDMO, is positioned to be your suitable drug product manufacturing partner.

By using a quality-by-design approach we are able to offer a completely digitalized workflow, allowing our clients and partners to access all information via a secure online portal.

Through our partnership with Cytiva we have access to the most advanced sterile filling equipment on the market to date.



**White Raven, a CDMO, specialized in GMP Formulation and Aseptic filling for sterile injectables, ensures on-time delivery of your high valued pharmaceutical products by using state-of-the-art sterile processing and ensuring industry quality-related standards.**

Our drug product manufacturing services have been tailored to the every changing pharmaceutical market, from small molecules to ATMPs, we provide a high degree of flexibility, our client' requirements and timeline constraints.

We understand that timelines might vary during the development of your products and for that reason we have designed tailored flexibility offerings that match your milestone dates and allow you to reassuredly focus on developing your products.

## Industries

---

- Small size batches of commercial products
- Early & Late stage clinical productions
- Pre-clinical productions (toxicity studies)
- Biologics
- Gene therapies
- mRNA
- Potent compounds
- mAbs
- Peptides
- Oligonucleotides
- Small Molecules

# From Quotation to Release

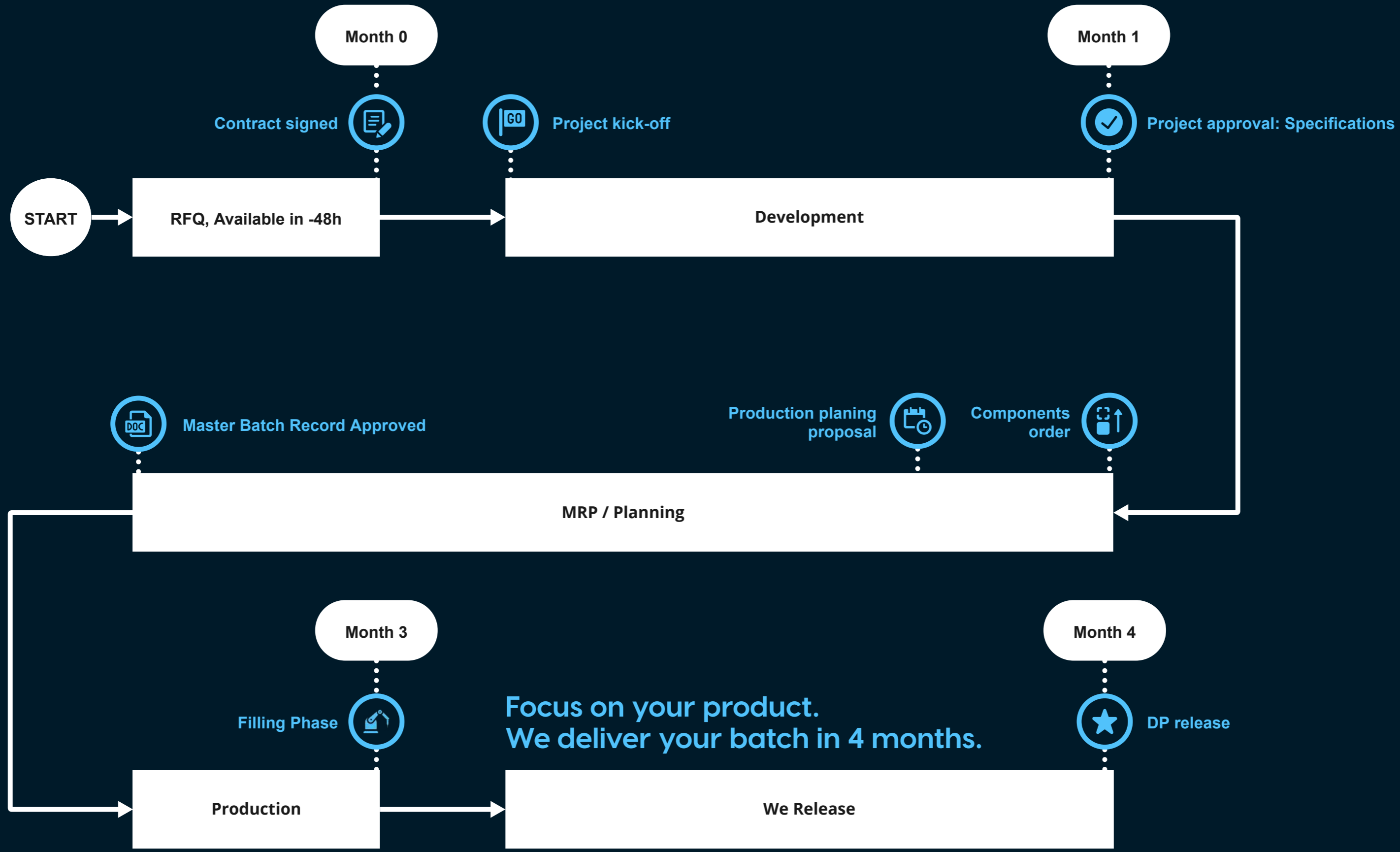

# Formulation: Bottle Mixer

## Formulation development and production



Scan or click to learn more

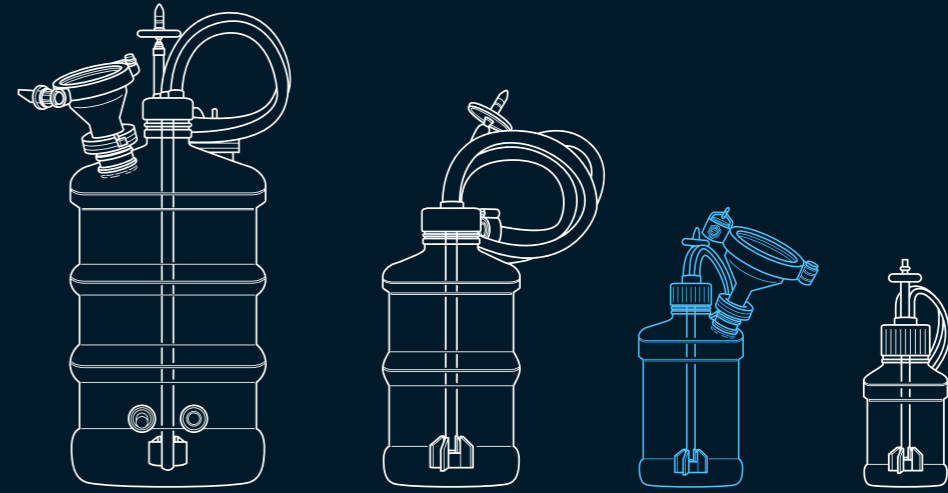

## Key Features

We provide a diverse range of formulation services adapted to small batches, with the capability to work with mixing volumes as low as 50mL, and up to 50L.

Single use approach.

Sterile or non-sterile mixing.

No CapEx for our customers.

Integrated in our IT process reducing human error risk.

High chemical compatibility - Extensive extractable package and very low particle load.

Active substance / Placebo / Diluent / Adjuvant.

Pooling / Dilution.

Powder (API) dissolution.



## Specifications & range

Fully closed single-use system.

Formulation volume range : 50mL to 50L.

Sterility Assurance Level 10<sup>-6</sup> (ISO11137)

Animal Derived Component Free (ADCF)

## Benefits

Agile mixing: Match your needs without CapEx investment.

Single use: No contamination or mixing error.

Low shear forces: Low degradation and aggregate formation on your sensitive protein.

High chemical compatibility.

Low extractables and particles generation.

# Formulation: Isolator

## Formulation development and production



Scan or click to learn more

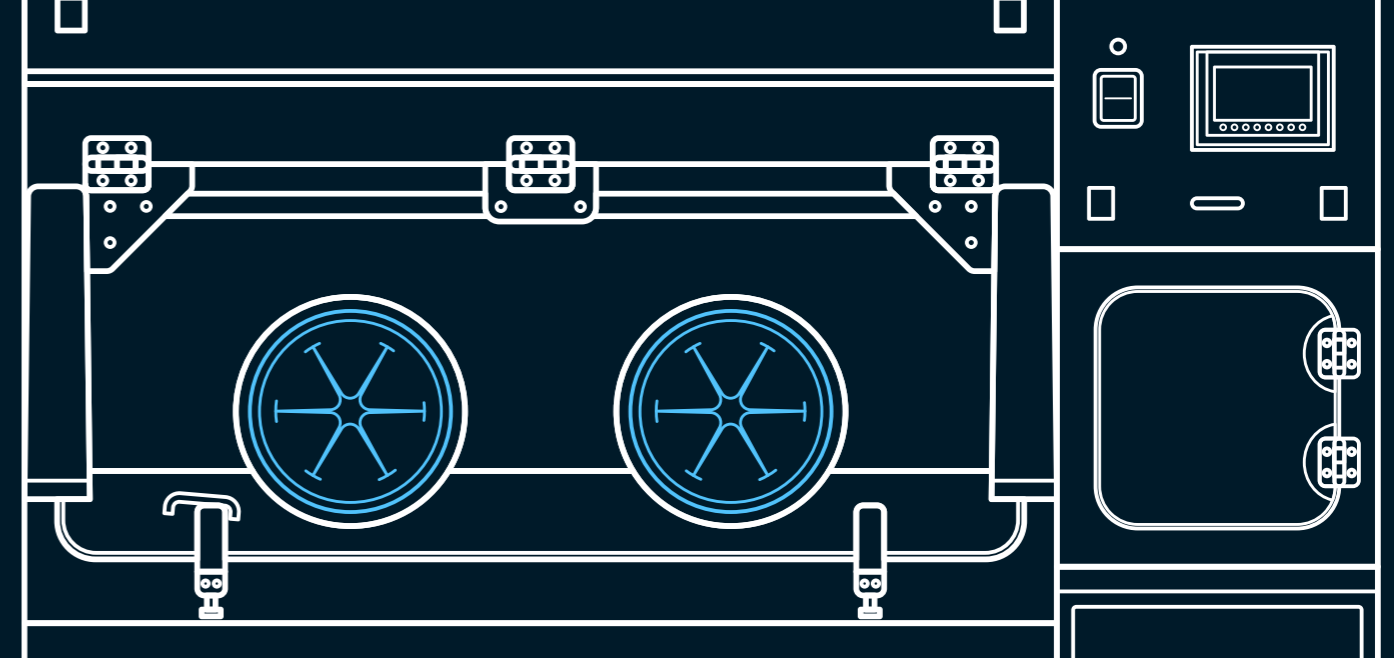

## Key Features

High containment unit to perform sensitive weighing or formulation activities

H14 HEPA air filtration.

H2O2 decontamination system.

RTP port connection.

Airlock with dedicated decontamination system.

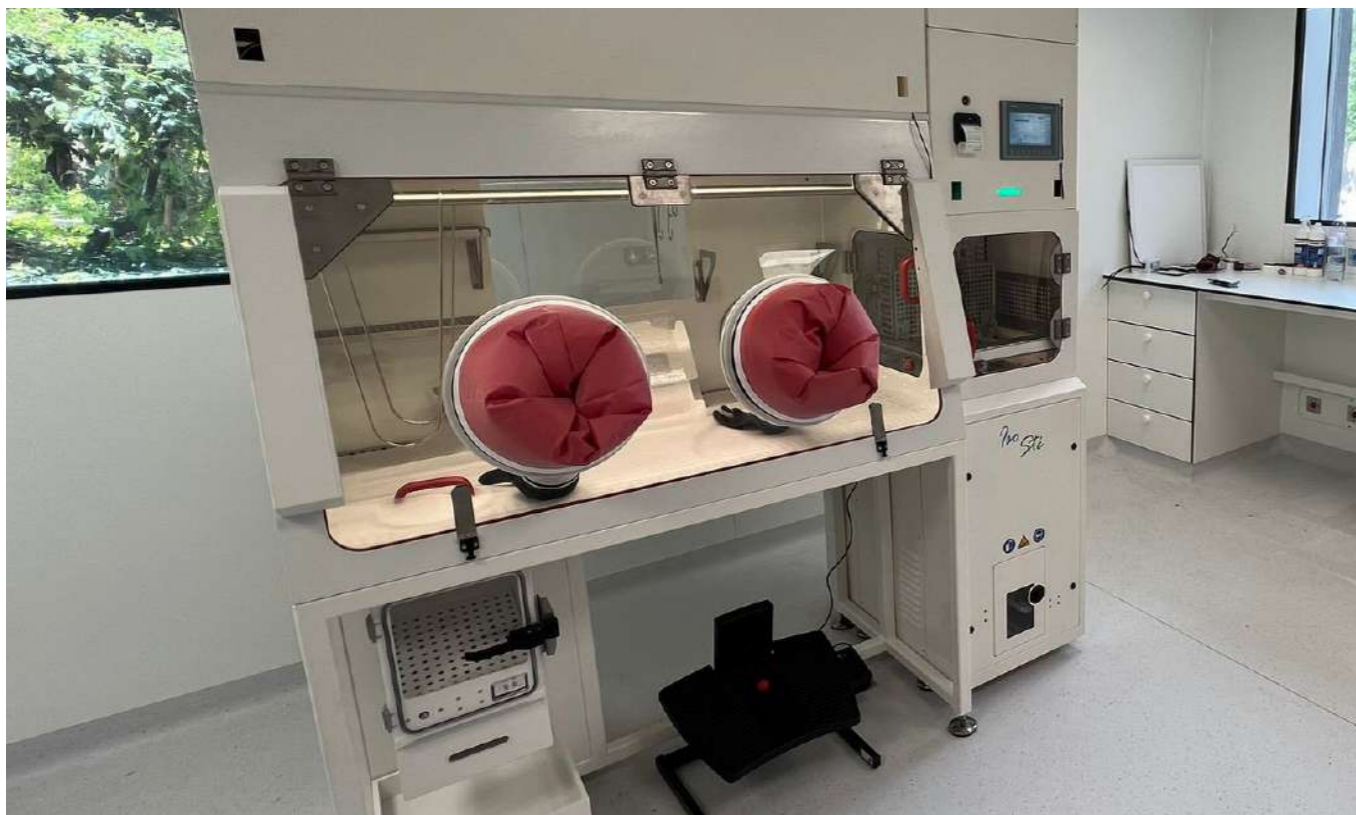

## Specifications & range

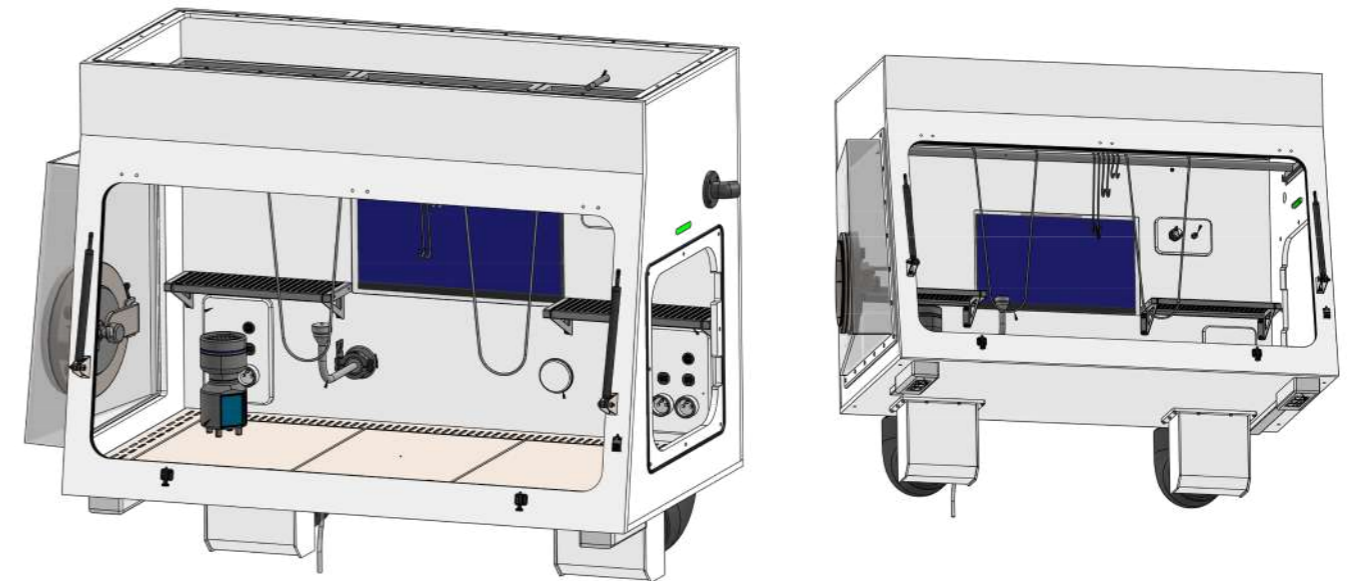

Integrated hydrogen peroxide bio-decontamination device Isosté H+.

Dynamic aeration and a 20-minute bio-decontamination cycle for the rapid airlock.

H14 HEPA filters on air intake and exhaust with 99.995% MPPS efficiency.

## Benefits

Superior containment system to protect your product.

Flexible isolator to match your sterile/contained weighing and formulation activities.

# Aseptic Filling

## Robotic Gloveless Isolator



Scan or click to learn more

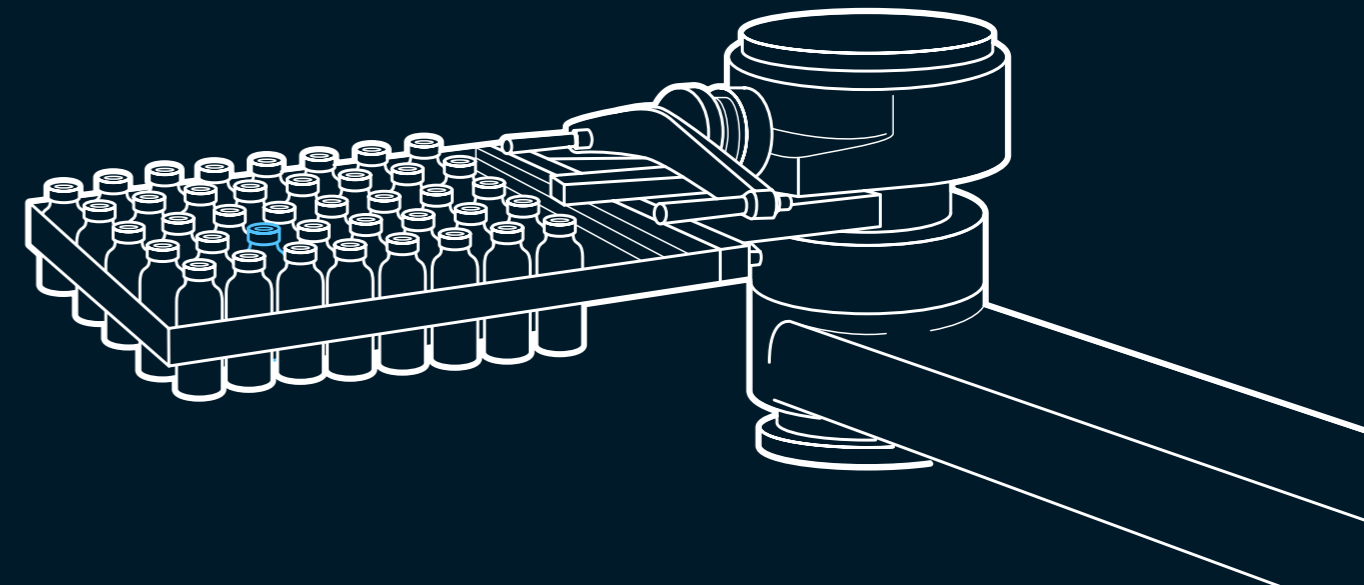

### Key Features



From 100 to 20 000 units per batch.

No glove ports, no human interaction, no contamination.

Fill nested vial, syringe, or cartridge with fill volume from 0.2 to 100mL.

Quick changeover between formats.

### Specifications & range

Gloveless robotic isolator, removing, by design, any risk of contamination.

Container size (all containers sizes available in nested tubs):

- Vials: 2R – 100H
- Syringes: 0.5 – 20mL
- Cartridges 1.5 ml – 20mL

Liquid products.

High efficiency product gazing with N2 or CO2.



### Benefits

Robotic gloveless isolator, sterile manufacturing at its finest.

Very low product losses:

- Optimized single use assemblies,
- Product recovery capability.

Removing risk of environmental contamination & cross contamination.

Able to handle very low batch sizes (particularly interesting for personalized medicine applications)

# Visual Inspection

## Manual Inspection Capabilities



Scan or click to learn more



## Key Features

**Tailored Inspection Processes:** to meet the unique specifications of each product, including but not limited to particle inspection, container integrity.

**Real-Time Quality Control:** visual inspection room directly connected to the filling room. Immediate identification and segregation of defects preventing potential contamination or spreading defect.

**Digital documentation :** All inspection activities are thoroughly digitally documented, providing transparent and traceable records.



## Benefits

**Enhanced Product Safety:** Minimizing the risk of contaminants and defects, ensuring the safety and efficacy of injectables, protecting patient health and your brand reputation.

**Regulatory Compliance:** Adhering strictly to GMP guidelines, our manual inspections help maintain compliance.

**Customized Support:** We adapt our services to align with your specific product needs and production schedules, offering flexible and responsive support.

# Packaging & Labelling

## Personalised Packaging & Labelling



Scan or click to learn more

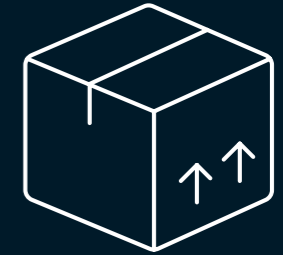

## Key Features

**Precision Handling and Packaging:** Skilled technicians for precise placement and protection of the product integrity.

**GMP-Compliant Labeling:** Adherence to Good Manufacturing Practices in every aspect of our labeling process.

**Customized Packaging Solutions:** to meet the specific requirements of your product (i.e. sensitivity to light and temperature).

**Batch Verification and Documentation:** Traceability and compliance.

## Benefits

**Compliance and Traceability:** Regulatory compliance and complete traceability,

**Reduced Risk of Errors:** Expert staff to reduce the risk of error,

**Flexibility in Production:** Manual processes allow for quick adjustments and customization needed for small batches.

# Our Production Facility

From clinical scale manufacturing to releasing your batch



Scan or click to learn more

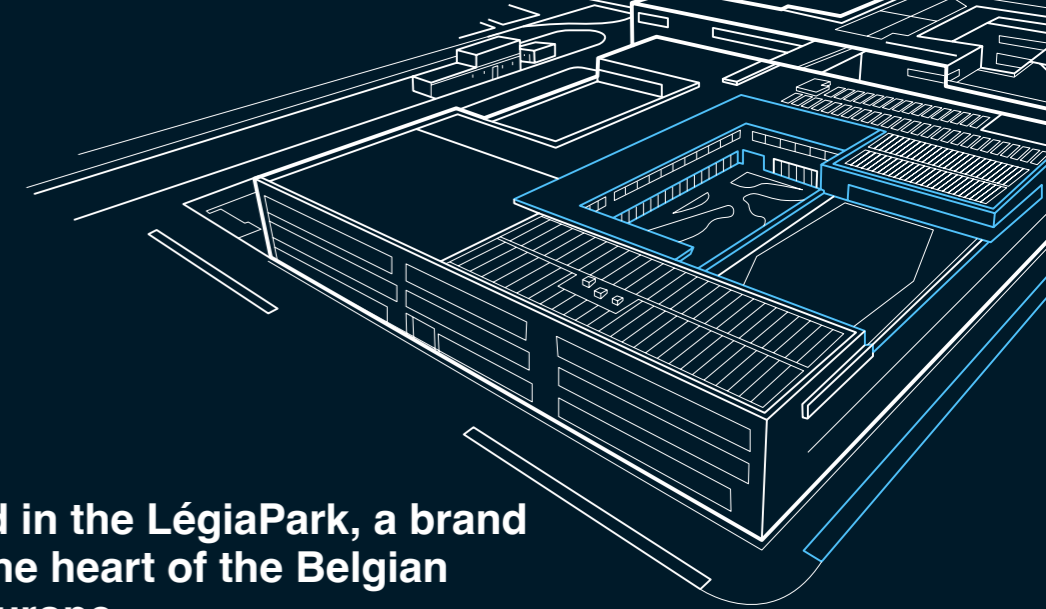

Our company is located in the LégiaPark, a brand new biotech center at the heart of the Belgian Biotech Valley and of Europe.

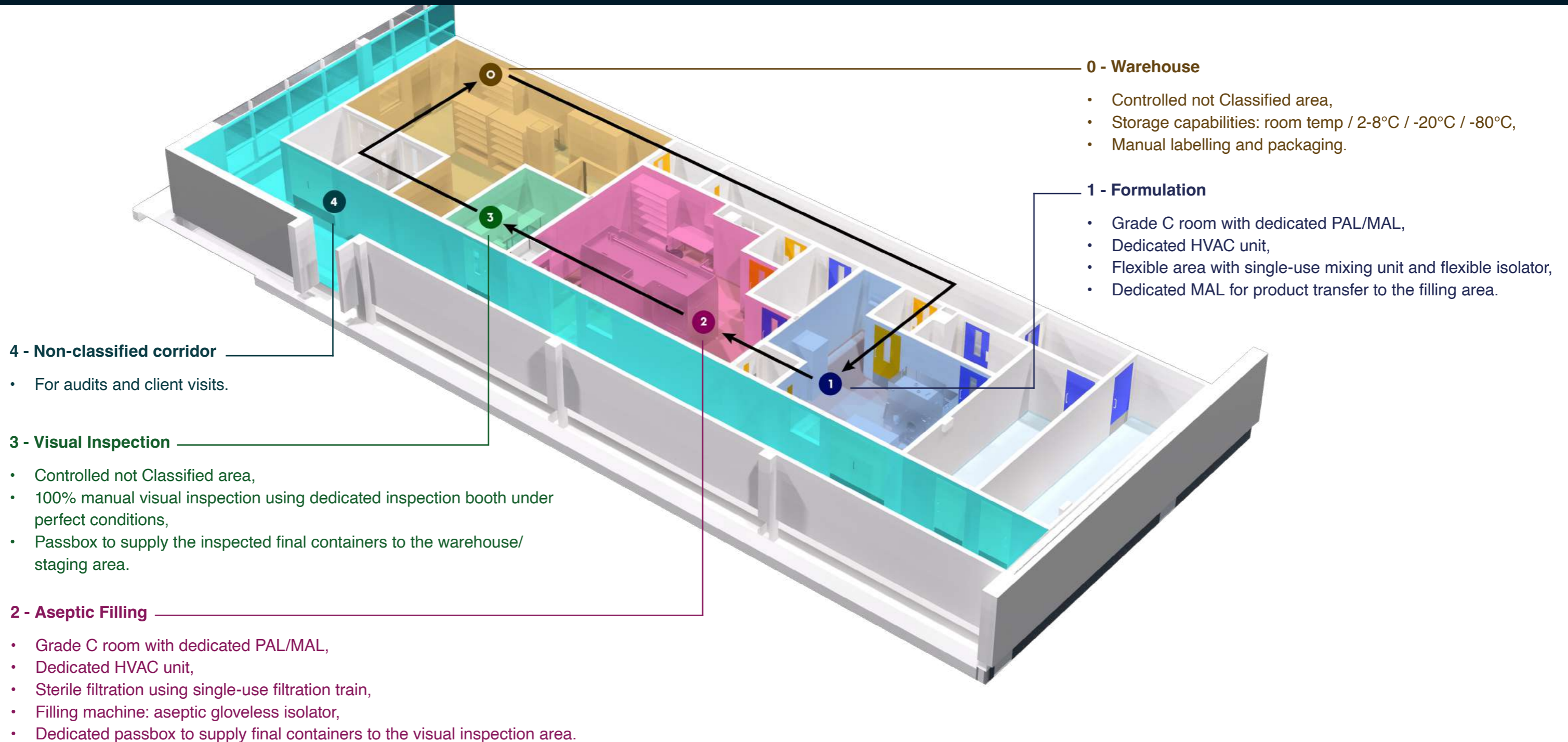

# Why Choose Us

Committed to supporting you by offering and maintaining industry quality standards, so your products reach the clinics and market safely and on time.



## Our Commitments

### Commit to Quality:

We are committed to delivering top-notch products and services, this commitment underscores our unwavering dedication to not only meet but surpass customer expectations.

### Commit towards Scientific Excellence:

We are dedicated to the pursuit of scientific excellence, experimentation, and product development.

### Commit to The Environmental Cause:

We are aware of our environmental impact. Therefore we are committed to minimizing our footprint.

### Commit to Transparency:

We operate in a fully transparent setting allowing our clients and partners.

### Commit to Pioneer Technologies:

We actively seek out technological and scientific advancements, we innovate to develop products and solutions that cater to evolving market demands.

## Unmatched Quality & Flexibility

Based on our quality-by-design approach through out the manufacturing operations, we operate solely with single-use consumables from the formulation operations to aseptic filling.

This allows us a high degree of flexibility between projects and batches, while also ensuring reduced risk of cross contaminations.

By working closely with our clients from day 1 we make sure any change is captured well in advance of the planned activities, and deadlines are met in timely manner.

Our robotic gloveless isolator plays a key role in ensuring control of the process and key filling parameters while being fully compliant with the latest regulatory updates.

By putting forward quality and flexibility we can adapt quickly to the ever changing pharmaceutical market and its quality standards. It's therefore of utmost importance to partner with a suitable fill & finish CDMO such as White Raven.

White Raven is your efficient, flexible, and customer-oriented CDMO partner allowing you to meet your clinical trial manufacturing needs with state-of-the-art technology, fully digital process, and agile management style.

## Contact us

Leave a message:



scan or click

## Follow us

Linkedin: @white\_raven



scan or click

## Book a meeting

Meet our team:



scan or click

## Learn more

Visit our website:



scan or click

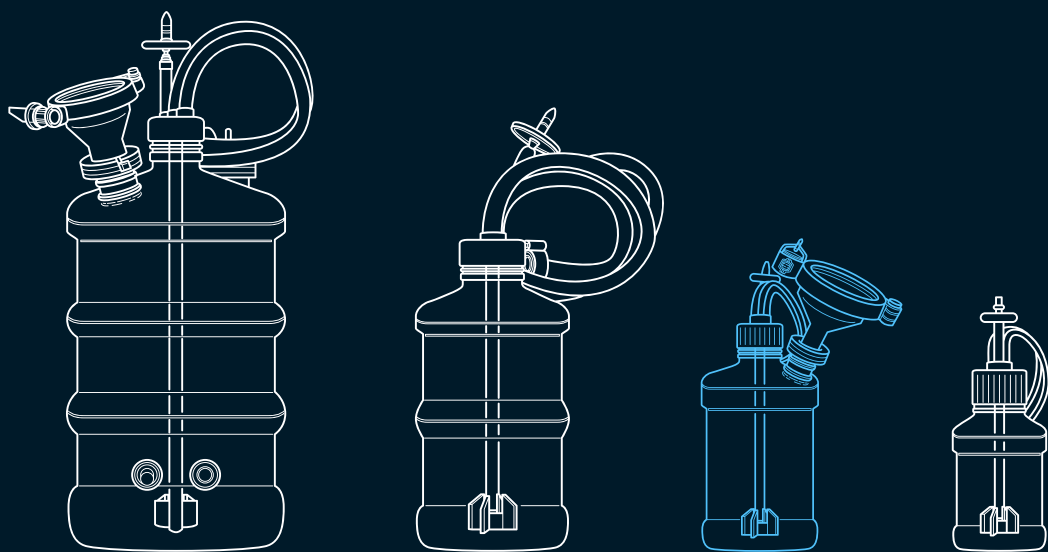

**#WeRelease**